

# WIPCOOL<sup>®</sup>

IDEAL PRODUCTS FOR HVAC

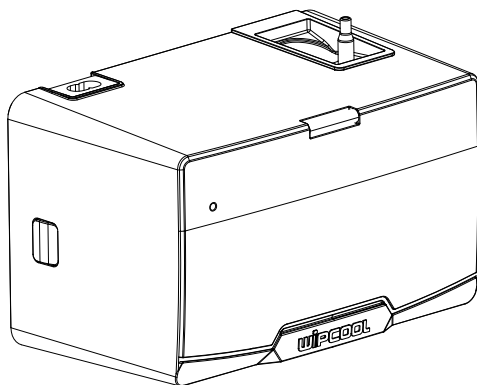

## P130 Condensate Pump

-Operation Manual-

## 1. Notice Before Usage

Thank you for choose WIPCOOL condensate pump, we are dedicated to providing you with high quality products.

Please check if your ordered product is in good shipment condition with the correct accessories, any damage during transportation, please contact us or the local distributors in time.

This manual gives instructions on the correct operation, it's important that you follow this instructions carefully.

If there is any change in the product (including the specification), we won't inform you any more.

## 2. In The Box

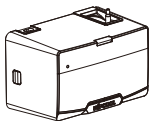

x 1  
Pump

### Accessories



plug x 2



screw x 2



plate x 1



cable x 1



x 1

## 3. Diemensions

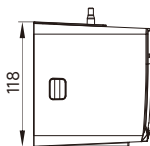
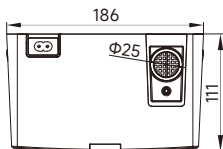
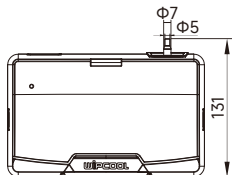





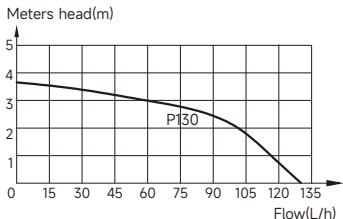

## 4. Technical Data

Model	P130
Voltage	100V-230V~/50-60Hz
Discharge Head(max.)	3.5m(12ft)
Flow Rate(max.)	130L/h(34GPH)
Suitable For	150,000btu/h
Tank Capacity	650mL
Sound Level at 1m	25dB(A)
Ambient Temp.	0°C - 50°C
Power Consumption	10W



## 5. Safety Instructions

-  1. Place the tank horizontal when installing, do not tilt the pump. Check whether the level drop is centered; if there is tilt, adjust the water level before using it.
-  2. Do not place electrical appliances or valuables under the condensate pump to avoid loss caused by power failure or water leakage.
-  3. Non - professional personnel should not install it to avoid danger.
-  4. The condensate pump is not waterproof. Do not place it in the open air, outdoors or in a place prone to flooding.
-  5. The condensate pump power supply needs to be independent to maintain permanent power supply. For details of connecting with air conditioning system, please refer to the wiring diagram.
-  6. It is prohibited that the water inflow is bigger than our stated flow rate, which will easily cause the motor to work continuously and fail. Instant big water inflow will also cause the condensate pump fail to discharge water in time, leading to water leakage.

## 6. Installation Procedure

- (1) Cut off the power.
- (2) Select location at the lower left or right\* of the air conditioner.
- (3) Make holes in the wall according to the location for installation and then fix the hang plate on the wall.

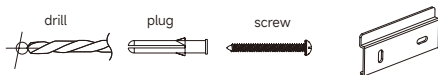

- (4) Remove the shock pad

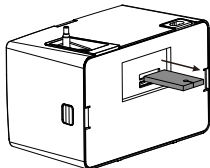

- (5) Hang the pump on the plate and make the installation is horizontal.

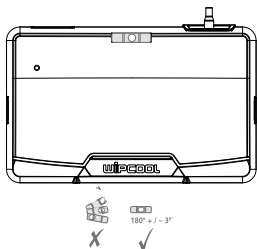
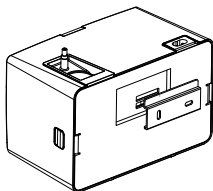

- (6) Insert the air conditioner drain hose all the way into the reservoir and connect the pump's discharge hose to the external drain hose. (At this time, be careful that the air conditioner drain hose does not interfere with the water level sensor inside the product water container.)
  - Hose standard: 6mm or 1/4" (inner diameter) x 9mm or 3/8" (outer diameter)
  - Be careful not to kink or pinch off the hose if bending.

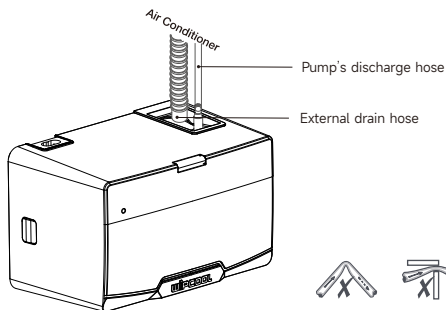

- (7) Ensure that power is shut off to the air conditioning unit. Connect the power cable of the pump to the respective power terminals. Power should be continuously supplied to this equipment except when maintenance or follow-up service is carried out.

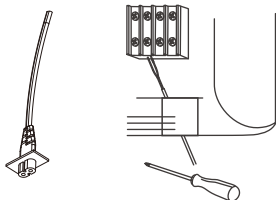

Test the pump after installation:

Pour a little water into the drain pan of the air conditioner's indoor unit.

When the water level increases to pump's starting lever, it will start discharging the water, and then turn off. Repeat this step 8-10 times. Check any leakage of water or generation of abnormal noise while the pump runs.

Though there may be a loud noise in the first 1-2 operations until the entering air escapes and the pump is primed, this is not a failure.



Disconnect all electrical power before starting installation, maintenance, or service work.

## 7. Maintenance

1. Be sure to maintain the equipment in the following order when you stop operation of the air conditioner after summer season or resume operation of the air conditioner in early summer.
2. Be sure to cut off the power supply before maintaining this equipment
3. Remove the cover. Remove the reservoir by pushing the hook like tab closest to the edge of the pump (have a towel prepared in case some water spills out). Detach the hose at the outlet of the reservoir. Keep the spring inside of the hose.

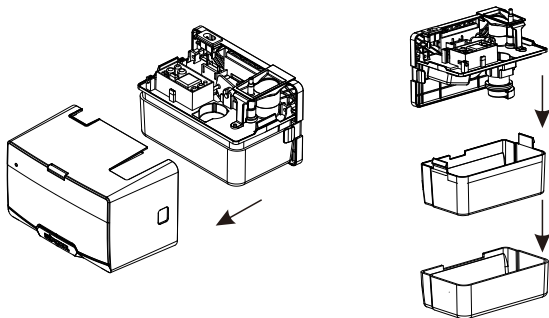

4. Wash the inside of the reservoir and float with water and mild soap.

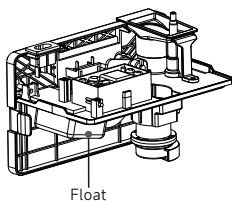

Float

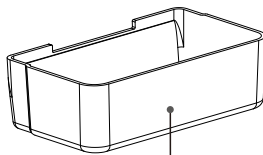

Reservoir

## 8. Troubleshooting

Problem	Cause	Action
Pump runs all the time	1. Installation is not horizontal	Adjust the tank make it level
	2.The shock pad is not removed	Remove the shock pad
Pump makes loud noise	1. The water is siphoning back in the pump	Check whether the outlet pipe is lower than pump thus result in siphoning, raise the condensate pump position
Pump can't start working	1. Installation is not horizontal	Adjust the tank, check water level
	2. The power can't reach pump	Check power supply
	3. The voltage isn't correct	Check the voltage